

ELECOR™

**Steel EMT
Electrical
Fittings
Catalog**

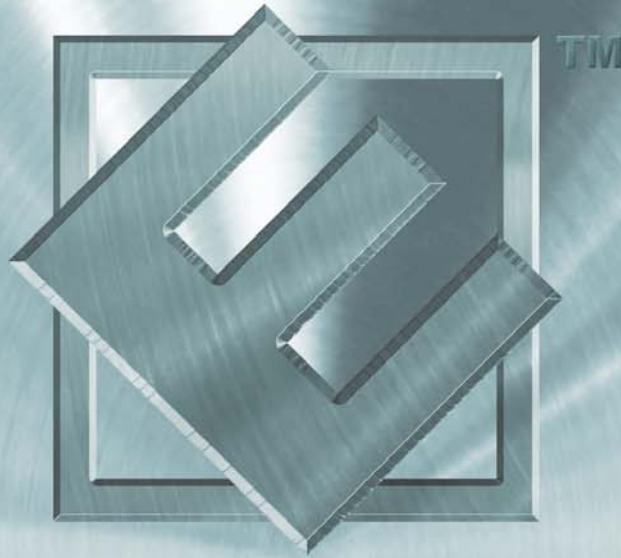

Terms and Conditions of Sale

DISTRIBUTOR TERMS AND CONDITIONS

GENERAL INFORMATION:

AGREEMENT:

These Terms and Conditions and the provisions hereof constitute the entire agreement between Elecor and the buyer and supercede all statements, representations and agreements, oral or written made by the parties or their representatives including, without limitation, conflicting or different provisions of Buyer's purchase order. No modification or addition to this agreement shall be binding upon Elecor, unless specifically set forth in writing, signed by Elecor.

TERMS:

2% 10th prox., NET 25th of month. Invoices dated 1st through the 25th are due the 10th of the following month to qualify for the 2% cash discount. Invoices dated 26th through 31st, inclusive, are payable the 10th of the next following month to qualify for the 2% cash discount. After the 25th of the following month, a monthly service charge of 11/2% will be applied, unless that rate exceeds the maximum lawful rate, then the maximum lawful rate will be used.

PRICES:

Pricing is subject to change without prior notice. Orders will be invoiced at the pricing in effect at the time of shipment unless otherwise stated. Price quotations will be valid for thirty (30) days from the date of quotation unless expressly written otherwise by Elecor.

MINIMUM BILLING:

A minimum billing charge of \$100.00 net will be made on all orders. Next day express shipments are not subject to minimum billing requirements.

BROKEN CARTONS:

Orders for broken cartons will not be allowed. Orders will be increased to full carton quantities and invoiced accordingly.

DELIVERY:

Qualified shipments, within the continental U.S., will be made prepaid by surface freight, F.O.B. shipping point, to one destination. Freight on qualified shipments to destinations outside the Continental U.S. (including Alaska and Hawaii) will be prepaid and allowed to the U.S. port of export only. Elecor reserves the right to use its own discretion in routing shipments for which Elecor assumes transportation charges. If the purchaser specifies a more expensive routing, the purchaser must assume all transportation charges. Premium freight charges are the responsibility of the purchaser and are not subject to cash discount.

SHIPPING AND FREIGHT TERMS:

Orders valued less than \$1,000.00 Distributor Net Cost will be subject to actual transportation charges as invoiced by the carrier.

WEIGHTS AND DIMENSIONS:

Catalog weight and dimensions are approximate and subject to change without notice.

ORDER ACCEPTANCE:

All sales are expressly limited to these terms and conditions and the right and intentions of the parties shall be governed exclusively by terms and conditions hereof. Where there is any conflict as to whether the Seller's terms and conditions govern the contract, receipt and acceptance, whether under protest or otherwise, of the materials and supplies delivered hereunder shall be conclusive evidence of the acceptance by the purchaser of the contract on all the Seller's terms. Elecor accepts orders and bills at current published prices and terms even though incorrect prices and terms may appear on the Purchaser's order.

CLAIMS:

Claims by purchaser for billing errors, shortages, damages, freight charges or allowances of any kind must be made within 30 days from receipt of material.

A. Shortages/Damages: Under FOB shipping point terms, title of the material passes to the distributor when Elecor delivers the material to the carrier. It is the distributor's responsibility to resolve all shortage and damage claims directly with the carrier.

B. Payment Responsibility: Any claim against Elecor does not alter the distributor's responsibility to pay invoices when due.

CANCELLATION:

Orders for Specials, or standard goods in quantities larger than normal inventory, may NOT be cancelled once the order is placed in production.

TAXES:

Published or quoted prices do not include sales taxes, excise, or similar taxes. Purchaser must pay all taxes.

SHIPPING DATE AND DELIVERY:

Every effort will be made to fill orders within the time stated. Under NO circumstances will seller be responsible for or the purchaser(s) entitled to consequential damages arising out of or owing to any delays in delivery whatever or for causes beyond seller's reasonable control.

Shipping date and delivery specified are subject to any priorities or allocations necessitated by government orders or regulations, and time and manner of delivery are subject to any delay on the part of the purchaser(s) in supplying necessary data, or by any changes in data at the purchaser(s) insistence, and/or to delays caused by fire, floods, strikes, lockouts, riots, war, breakdowns, priorities or embargoes, accidents, civil or military authority, shortages of labor, delay in suppliers (or supplies) of material, difficulty in obtaining raw material, and any other cause beyond seller's reasonable control. Delay in delivery for any of the aforementioned causes shall proportionately extend the time of delivery hereunder. Seller shall be compensated for any and all extra costs and expenses occasioned by delays attributable to the purchaser(s).

WARRANTY:

Elecor warrants its products for defects in material only, for a period of one year from the date of shipment from its plant or warehouse. Elecor shall not be held responsible for any damages incurred over and above the price of the products sold or any unauthorized repair. This warranty shall not apply to any product that shows evidence of neglect, misuse or improper installation, or that has been repaired or altered by any party other than this company. This warranty is and shall be in lieu of all other warranties, expressed or implied.

RETURNED GOODS:

Elecor agrees to accept from its distributor's stock only the return of products for merchandise credit subject to the following terms and conditions:

1. All requests for return authorizations must be submitted through your Elecor Representative.
2. Material to be returned must be in original standard quantity cartons. Special orders, used, or damaged items will not be accepted. Unacceptable material will be destroyed and will not qualify for credit.
3. Returns will not be accepted unless accompanied by an Elecor "Return Material Authorization" (RMA).
4. Minimum value of returns must not be less than \$100.00 Dist. Net Cost, after restocking charge, if applicable.
5. Credit will not be issued for items not listed on the RMA.
6. Within 60 days of issuance, all returns must be shipped freight prepaid, unless otherwise instructed, to the Elecor warehouse specified on the RMA.
7. Credit will be given only for those products authorized on the RMA. Any non-authorized material will be scrapped or returned to distributor, freight collect, at the discretion of Elecor.
8. A merchandise credit will be issued at the prices reflected on the original invoice.
9. Deductions for returned material are not allowed. A credit memo will be issued after material has been received and inspected by our warehouse.
10. A 20% handling/restocking will be charged on returned material not related to an Elecor error.

CONTACT: ELECOR

13 Wood Street West Haven, CT 06516
1.888.466.8600 Fax: 203.937.3028
info@elecorfittings.com

Cross Reference/Product Index

Add the prefix 870263 to any Elecor UPC/DCI/NAED # to obtain the 11 digit Elecor UPC no.

Elecor Catalog No.	Elecor UPC/DCI/NAED	Elecor Page	O.Z. Gedney	Raco	T & B	Bridgeport	Appleton	Crouse-Hinds	Steel City
ES1101	00101	4	4050S	2002	5051	230	TW50-S	450S	TC121A
ES1102	00102	4	4075S	2003	5053	231	TW75-S	451	TC122A
ES1103	00103	4	4100S	2004	5055	232	TW100-S	452	TC123A
ES1104	00104	4	4125S	2005	5057	233	TW125-S	453	TC124A
ES1105	00105	4	4150S	2006	5059	234	TW150-S	454	TC125A
ES1106	00106	4	4200S	2008	5061	235	TW200-S	455	TC126A
ES1107	E 00107	4	4250S	2140	5063	236	TW250-S	456	TC127A
ES1107	R 00107	4	28-250	2140			SNTC-250	156-P I	TC127A
ES1108	E 00108	4	4300S	2142	5065	237	TW300-S	457	TC128A
ES1108	R 00108	4	28-300	2142			SNTC300	157-P I	TC128A
ES1109	E 00109	4	4350S	2144	5066	238	TW350-S	458	TC129A
ES1109	R 00109	4	28-350	2144			SNTC350	158-P I	TC129A
ES1110	E 00110	4	4400S	2146	5067	239	TW400-S	459	TC1210A
ES1110	R 00110	4	28-400	2146			SNTC-400	159-P I	TC1210A
ES1121	00111	4	4050ST	2122	5031	230-I	TW50-SI	1450	TC721A
ES1122	00112	4	4075ST	2123	5033	231-I	TW75-SI	1451	TC722A
ES1123	00113	4	4100ST	2124	5035	232-I	TW100-SI	1452	TC723A
ES1124	00114	4	4125ST	2125	5037	233-I	TW125-SI	1453	TC724A
ES1125	00115	4	4150ST	2126	5039	234-I	TW150-SI	1454	TC725A
ES1126	00116	4	4200ST	2128	5041	235-I	TW200-SI	1455	TC726A
ES1127	E 00117	4	4250ST	2160	5043	236-I	TW250-SI	1456	TC727A
ES1127	R 00117	4	28-250T	2160	8725		SRNTC-250	156 I	TC727A
ES1128	E 00118	4	4300ST	2162	5047	237-I	TW300-SI	1457	TC728A
ES1128	R 00118	4	28-300T	2162	8825		SRNTC-300	157 I	TC728A
ES1129	E 00119	4	4350ST	2164	5048	238-I	TW350-SI	1458	TC729A
ES1129	R 00119	4	28-350T	2164	8855		SRNTC-350	158 I	TC729A
ES1130	E 00120	4	4400ST	2166	5049	239-I	TW400-SI	1459	TC7210A
ES1130	R 00120	4	28-400T	2166	8975		SRNTC-400	159 I	TC7210A
ES1201	00121	5	5050S	2022	5030	240	TWC50-S	460	TK121A
ES1202	00122	5	5075S	2023	5032	241	TWC75-S	461	TK122A
ES1203	00123	5	5100S	2024	5034	242	TWC100-S	462	TK123A
ES1204	00124	5	5125S	2025	5036	243	TWC125-S	463	TK124A
ES1205	00125	5	5150S	2026	5038	244	TWC150-S	464	TK125A
ES1206	00126	5	5200S	2028	5040	245	TWC200-S	465	TK126A
ES1207	E 00127	5	5250S	2150	5042	246	TWC250-S	466	TK127A
ES1207	R 00127	5	29-250	2150	8724		SNTCC-250	166	TK127A
ES1208	E 00128	5	5300S	2152	5044	247	TWC300-S	467	TK128A
ES1208	R 00128	5	29-300	2152	8824		SNTCC-300	167	TK128A
ES1209	E 00129	5	5350S	2154	5045	248	TWC350-S	468	TK129A
ES1209	R 00129	5	29-350	2154	8851		SNTCC-350	168	TK129A
ES1210	E 00130	5	5400S	2156	5046	249	TWC400-S	469	TK1210A
ES1210	R 00130	5	29-400	2156	8971		SNTCC-400	169	TK1210A
ES2101	00131	6	7050S	2902	5121	250	TW-50	650S	TC111A
ES2102	00132	6	7075S	2903	5221	251	TW-75	651S	TC112A
ES2103	00133	6	7100S	2904	5321	252	TW-100	652	TC113A
ES2104	00134	6	7125S	2905	5421	253	TW-125	653	TC114A
ES2105	00135	6	7150S	2906	5521	254	TW-150	654	TC115A
ES2106	00136	6	7200S	2908	5621	255	TW-200	655	TC116A
ES2107	00137	6	7250S	2940		256	TW-250CS	656	TC117A
ES2108	00138	6	7300S	2942		257	TW-300CS	657	TC118A
ES2109	00139	6	7350S	2944		258	TW-350CS	658	TC119A
ES2110	00140	6	7400S	2946		259	TW-400CS	659	TC1110A
ES2121	00141	6	7050ST	2912	5123	250-I	TW-50CSI	1650	TC711A
ES2122	00142	6	7075ST	2913	5223	251-I	TW-75CSI	1651	TC712A
ES2123	00143	6	7100ST	2914	5323	252-I	TW-100CSI	1652	TC713A
ES2124	00144	6	7125ST	2915	5423	253-I	TW125-C SI	1653	TC714A
ES2125	00145	6	7150ST	2916	5523	254-I	TW-150CSI	1654	TC715A
ES2126	00146	6	7200ST	2918	5623	255-I	TW-200CSI	1655	TC716A
ES2127	00147	6	7250ST	2960		256-I	TW-250CSI	1656	TC717A
ES2128	00148	6	7300ST	2962		257-I	TW-300CSI	1657	TC718A
ES2129	00149	6	7350ST	2964		258-I	TW-350CSI	1658	TC719A
ES2130	00150	6	7400ST	2966		259-I	TW-400CSI	1659	TC7110A
ES2201	00151	7	6050S	2922	5120	260	TWC-50CS	660S	TK111A
ES2202	00152	7	6075S	2923	5220	261	TWC-75CS	661S	TK112A
ES2203	00153	7	6100S	2924	5320	262	TWC-100CS	662	TK113A
ES2204	00154	7	6125S	2925	5420	263	TWC-125CS	663	TK114A
ES2205	00155	7	6150S	2926	5520	264	TWC-150CS	664	TK115A
ES2206	00156	7	6200S	2928	5620	265	TWC-200CS	665	TK116A
ES2207	00157	7	6250S	2950		266	TWC-250CS	666	TK117A
ES2208	00158	7	6300S	2952		267	TWC-300CS	667	TK118A
ES2209	00159	7	6350S	2954		268	TWC-350CS	668	TK119A
ES2210	00160	7	6400S	2956		269	TWC-400CS	669	TK1110A

E = When used with EMT R = When used with Rigid I = Malleable Iron

Comparisons relate to function only. Items may not be identical. Elecor does not assume responsibility for errors.

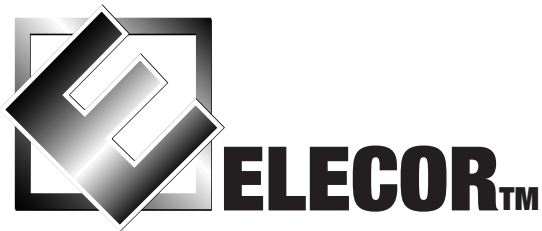

Steel Set-Screw Connectors

Applications

For use in location to bond EMT conduit to a box or enclosure

- Elecor steel set screw connectors provide concrete-tight connections when taped
- Elecor steel set screw connectors are suitable for applications above 600V

Features

- All steel construction ensures mechanical protection for the raceway
- Tri-head screws ($1/2$ " to 2" trade sizes) may be installed using a slotted, Phillips, or Robertson head screwdriver
- $2\frac{1}{2}$ " to 4" trade sizes are also UL listed for use with Rigid/IMC conduit, allowing for design and installation flexibility
- Available with insulated throat

Material / Finish

Steel/Zinc electro plated

Compliances

cULus listed

Standards

UL Standard: 514B
 CSA Standard: C22.2 No. 18
 Nema: FB-1
 Federal Spec: W-F-408E



$1/2$ " - 1"



$1\frac{1}{4}$ " - 2"



$2\frac{1}{2}$ " - 4"

NON-INSULATED		INSULATED		TRADE SIZE	CTN. QTY.	CASE QTY.	WEIGHT PER C
CATALOG NUMBER	UPC/DCI/NAED #	CATALOG NUMBER	UPC/DCI/NAED #				
ES1101	00101	ES1121	00111	$1/2$ "	50	250	9.37
ES1102	00102	ES1122	00112	$3/4$ "	25	125	11.25
ES1103	00103	ES1123	00113	1"	20	100	17.50
ES1104	00104	ES1124	00114	$1\frac{1}{4}$ "	10	50	38.12
ES1105	00105	ES1125	00115	$1\frac{1}{2}$ "	10	50	40.62
ES1106	00106	ES1126	00116	2"	5	25	57.50
ES1107	00107	ES1127	00117	$2\frac{1}{2}$ "	-	10	114.37
ES1108	00108	ES1128	00118	3"	-	5	154.37
ES1109	00109	ES1129	00119	$3\frac{1}{2}$ "	-	5	226.87
ES1110	00110	ES1130	00120	4"	-	5	264.37

DIMENSIONS

CATALOG NUMBER	CATALOG NUMBER	TRADE SIZE	DIM. A	DIM. B	DIM. C
ES1101	ES1121	$1/2$ "	1.400	.406	.87
ES1102	ES1122	$3/4$ "	1.500	.406	1.10
ES1103	ES1123	1"	1.625	.438	1.36
ES1104	ES1124	$1\frac{1}{4}$ "	2.313	.563	1.73
ES1105	ES1125	$1\frac{1}{2}$ "	2.500	.625	1.97
ES1106	ES1126	2"	2.812	.625	2.45
ES1107	ES1127	$2\frac{1}{2}$ "	3.250	.875	3.10
ES1108	ES1128	3"	3.750	.875	3.72
ES1109	ES1129	$3\frac{1}{2}$ "	4.000	1.000	4.24
ES1110	ES1130	4"	4.187	1.000	4.74

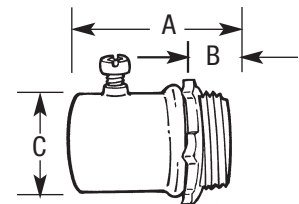

ES1101 - ES1103
 Sizes $1/2$ " - 1" are manufactured as shown above

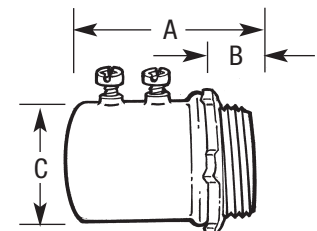

ES1104 - ES1106
 Sizes $1\frac{1}{4}$ " - 2" are manufactured as shown above

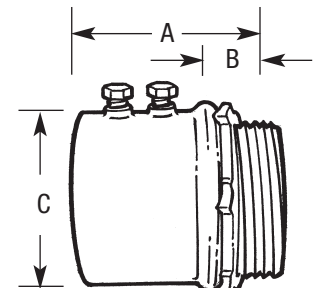

ES1107 - ES1110
 Sizes $2\frac{1}{2}$ " - 4" are manufactured as shown above

Screws on $1/2$ "-2" connectors are designed for slotted, Phillips, or Robertson head screw drivers



All set screw connectors available with insulated throat

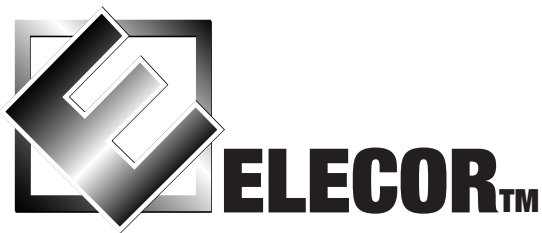

Steel Set-Screw Couplings

Applications

- Use to join two ends of EMT conduit
- Elecor steel set screw couplings provide concrete-tight connections when taped
- Elecor steel set screw couplings are suitable for applications above 600V

Features

- All steel construction ensures mechanical protection for the raceway
- Tri-head screws (1/2" to 2" trade sizes) may be installed using a slotted, Phillips, or Robertson head screwdriver
- 2 1/2" to 4" trade sizes are also UL listed for use with Rigid/IMC conduit, allowing for design and installation flexibility

Material / Finish

Steel/Zinc electro-plated

Compliances

listed

Standards

UL Standard: 514B
 CSA Standard: C22.2 No. 18
 Nema: FB-1
 Federal Spec: W-F-408E

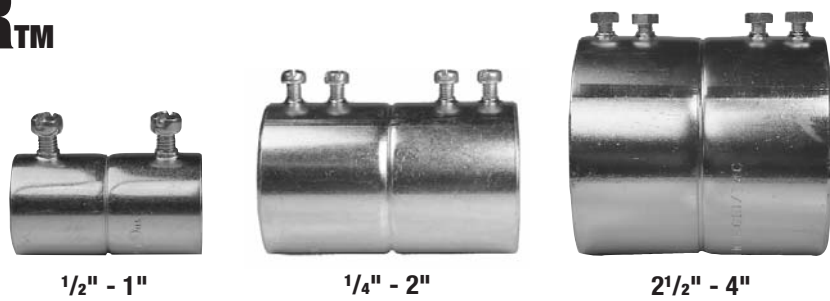

CATALOG NUMBER	UPC/DCI/NAED #	TRADE SIZE	CTN. QTY.	CASE QTY.	WEIGHT PER C.
ES1201	00121	1/2"	50	250	8.12
ES1202	00122	3/4"	25	125	12.50
ES1203	00123	1"	20	100	21.25
ES1204	00124	1 1/4"	10	50	39.37
ES1205	00125	1 1/2"	10	50	51.25
ES1206	00126	2"	5	25	63.75
ES1207	00127	2 1/2"	-	10	131.87
ES1208	00128	3"	-	5	162.50
ES1209	00129	3 1/2"	-	5	251.25
ES1210	00130	4"	-	5	275.00

DIMENSIONS

CATALOG NUMBER	TRADE SIZE	DIM. A	DIM. B
ES1201	1/2"	1.750	.840
ES1202	3/4"	2.130	1.055
ES1203	1"	2.500	1.310
ES1204	1 1/4"	3.250	1.675
ES1205	1 1/2"	3.750	1.920
ES1206	2"	4.000	2.375
ES1207	2 1/2"	4.250	3.150
ES1208	3"	4.500	3.765
ES1209	3 1/2"	4.750	4.330
ES1210	4"	5.000	4.820

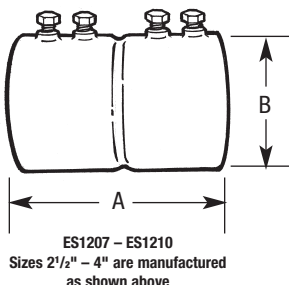
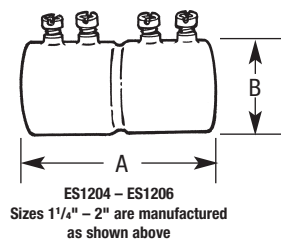
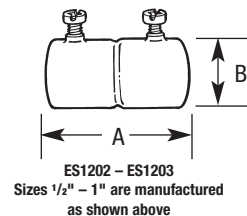

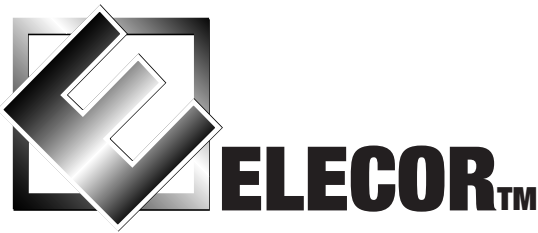

Steel Compression Connectors



1/2" - 4"

Applications

- For use in location to bond EMT conduit to a box or enclosure
- Elecor steel compression connectors provide concrete-tight connections
- Elecor steel compression connectors are suitable for applications above 600V

Features

- All steel construction ensures mechanical protection for the raceway
- Prominent hex/octagonal compression nuts assure easy installation
- Male hub threads N.P.S.
- Available with insulated throat

Material / Finish

Steel/Zinc electro-plated

Compliances

cULus listed

Standards

- UL Standard: 514B
- CSA Standard: C22.2 No. 18
- Nema: FB-1
- Federal Spec: W-F-408E

NON-INSULATED		INSULATED		TRADE SIZE	CTN. QTY.	CASE QTY.	WEIGHT PER C
CATALOG NUMBER	UPC/DCI/NAED #	CATALOG NUMBER	UPC/DCI/NAED #				
ES2101	00131	ES2121	00141	1/2"	50	250	11.87
ES2102	00132	ES2122	00142	3/4"	25	125	17.50
ES2103	00133	ES2123	00143	1"	20	100	25.00
ES2104	00134	ES2124	00144	1 1/4"	10	50	42.50
ES2105	00135	ES2125	00145	1 1/2"	10	50	56.25
ES2106	00136	ES2126	00146	2"	5	25	68.75
ES2107	00137	ES2127	00147	2 1/2"	-	10	150.62
ES2108	00138	ES2128	00148	3"	-	5	223.12
ES2109	00139	ES2129	00149	3 1/2"	-	5	287.50
ES2110	00140	ES2130	00150	4"	-	5	328.12

DIMENSIONS

CATALOG NUMBER	CATALOG NUMBER	TRADE SIZE	DIM. A	DIM. B
ES2101	ES2121	1/2"	1.800	1.093
ES2102	ES2122	3/4"	1.935	1.375
ES2103	ES2123	1"	2.110	1.778
ES2104	ES2124	1 1/4"	2.800	2.222
ES2105	ES2125	1 1/2"	3.130	2.459
ES2106	ES2126	2"	3.290	3.019
ES2107	ES2127	2 1/2"	3.465	3.940
ES2108	ES2128	3"	4.015	4.670
ES2109	ES2129	3 1/2"	4.215	5.010
ES2110	ES2130	4"	4.410	5.500

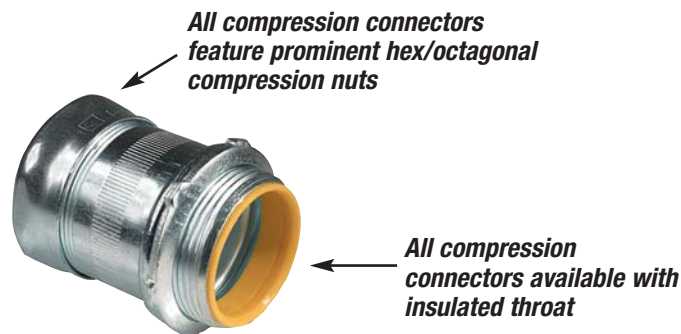
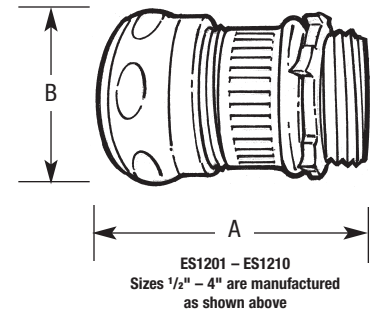

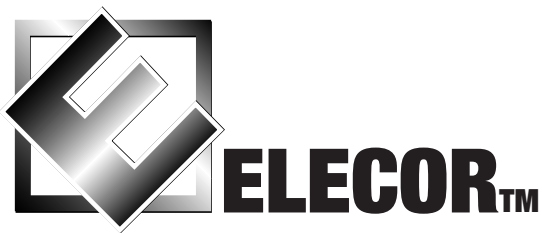

Steel Compression Couplings

Applications

- Use to join two ends of EMT conduit
- Elecor steel compression couplings provide concrete-tight connections
- Elecor steel compression couplings are suitable for applications above 600V

Features

- All steel construction ensures mechanical protection for the raceway
- Prominent hex/octagonal compression nuts assure easy installation

Material / Finish

Steel/Zinc electro-plated

Compliances

cUL_{us} listed

Standards

UL Standard: 514B

CSA Standard: C22.2 No. 18

Nema: FB-1

Federal Spec: W-F-408E



1/2" - 4"

CATALOG NUMBER	UPC/DCI/NAED #	TRADE SIZE	CTN. QTY.	CASE QTY.	WEIGHT PER C
ES2201	00151	1/2"	50	250	12.50
ES2202	00152	3/4"	25	125	21.25
ES2203	00153	1"	20	100	28.12
ES2204	00154	1 1/4"	10	50	46.25
ES2205	00155	1 1/2"	10	50	56.87
ES2206	00156	2"	5	25	75.62
ES2207	00157	2 1/2"	-	10	188.75
ES2208	00158	3"	-	5	270.00
ES2209	00159	3 1/2"	-	5	335.62
ES2210	00160	4"	-	5	393.12

DIMENSIONS

CATALOG NUMBER	TRADE SIZE	DIM. A	DIM. B
ES2201	1/2"	1.820	1.093
ES2202	3/4"	2.150	1.375
ES2203	1"	2.950	1.778
ES2204	1 1/4"	3.140	2.222
ES2205	1 1/2"	3.230	2.459
ES2206	2"	3.340	3.019
ES2207	2 1/2"	4.095	3.940
ES2208	3"	4.200	4.670
ES2209	3 1/2"	4.450	5.010
ES2210	4"	5.000	5.500

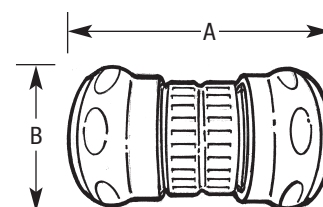

ES2201 - ES2210
Sizes 1/2" - 4" are manufactured as shown above

All compression couplings feature prominent hex/octagonal compression nuts

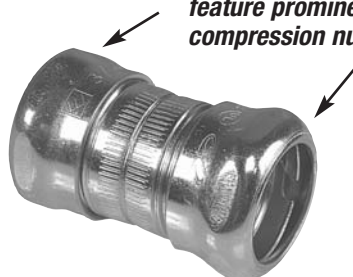

We appreciate your interest in Elecor and will strive to earn your trust everyday. We know you have many manufacturers to choose from and that our product and performance must be head and shoulders above the rest to maintain your confidence and your business. We promise that our dedication and hard work will make your job easier.

*Sincerely,
The Elecor Team*

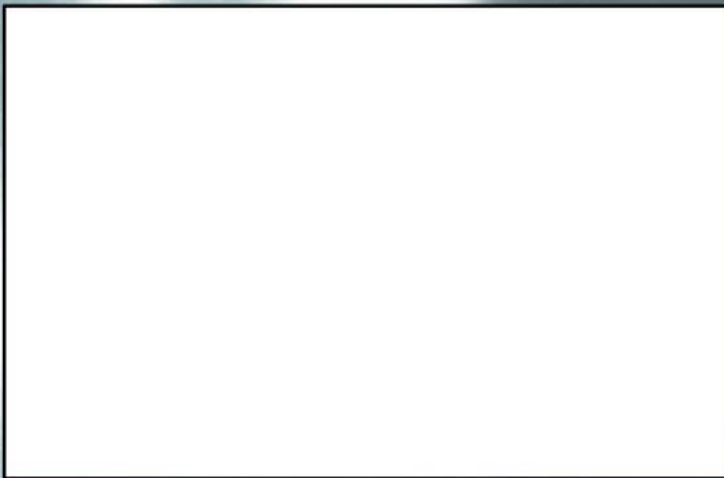

Elecor LLC
13 Wood St.
West Haven, CT
06516

www.elecorfittings.com
toll free: 888.466.8600
fax: 203.937.3028

© 2005 Elecor. All rights reserved

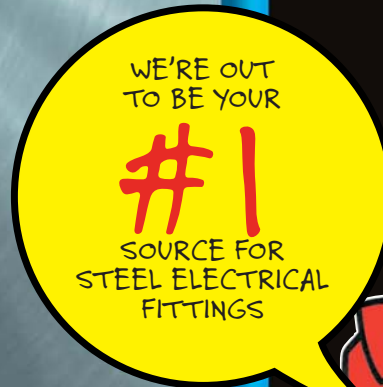

TM
FC1105*
(Rev. 03/06)